

Suitable for all gaseous and liquid media that will not obstruct the pressure system or attack copper alloy parts. Useful for systems that are not submitted to strong vibrations. Specially designed for pneumatics and hydraulics.



How to order:
M 02 01 + chosen options.

2. CONSTRUCTION / DESIGN

2.1. Design		EN 837-1
2.2. Mounting	x	Direct: Free standing on the radial/rear screwed connection
2.3. Degree of Protection		IP 44 per EN 60529 / IEC 529

3. MATERIALS AND DIMENSIONS

3.1. Case		
3.1.1. Material		Carbon Steel coloured in black
3.1.2. Nominal size	x	63, 75 and 100mm
3.2. Bezel ring		
3.2.1. Material		Carbon Steel coloured in black
3.2.2. Seal		pressure sealed
3.3. Internal elements		
3.3.1. Materials		Elastic element and movements in copper alloy. Tin soft welding and copper alloy soldering for pressure under 40 bar. For pressures over 40bar in copper and silver alloy.
3.3.2. Structure		Elastic element: With "C" type for pressures up to 40 bar and in spring type for pressures over 40 bar.
3.4. Screwed connection		
3.4.1. Material		Brass
3.4.2. Thread		1/4" BSP for Ø63mm, 3/8" BSP for Ø75 and 1/2" BSP for Ø100mm. In accordance with UNE-EN 10226-1
3.5. Window		Acrylic.
3.6. Dial		White lacquered aluminium.
3.7. Pointer		Aluminium anodized in black.

4. PRESSURE

4.1. Range	x	Pressure gauges: 0+0,6 0+1 0+1,6 0+2,5 0+4 0+6 0+10 0+12 0+16 0+25 0+40 0+60 0+100 0+160 0+250 0+315 0+400 0+600 0+1000 Compound gauges: -1+0,5 -1+1,5 -1+3 -1+5 -1+9 -1+15 -1+24 Vacuum gauge: -1+0
4.2. Scale		Double scale, black coloured for Bar and red coloured for Psi
4.3. Subdivision		In accordance with EN 837-1
4.4. Accuracy/ Class		Class 2.5 for Ø63 Class 1.6 for Ø75 and Ø100
4.5. Use conditions::		
4.5.1. Pressure conditions:		Steady: 3/4 of full scale value. Fluctuating 2/3 of full scale value Maximum pressure: (for short time) Full scale value.
4.5.2. Operating temperature:		Ambient: -40+80°C Medium: 100°C maximum

5. OPTIONS

5.1. Antivibration system		No
5.2. Logotypes		Optional: Customer's logo printed
5.3. Other connection threads		1/8" BSPT 1/4" BSPT 3/8" BSPT 1/2" BSPT

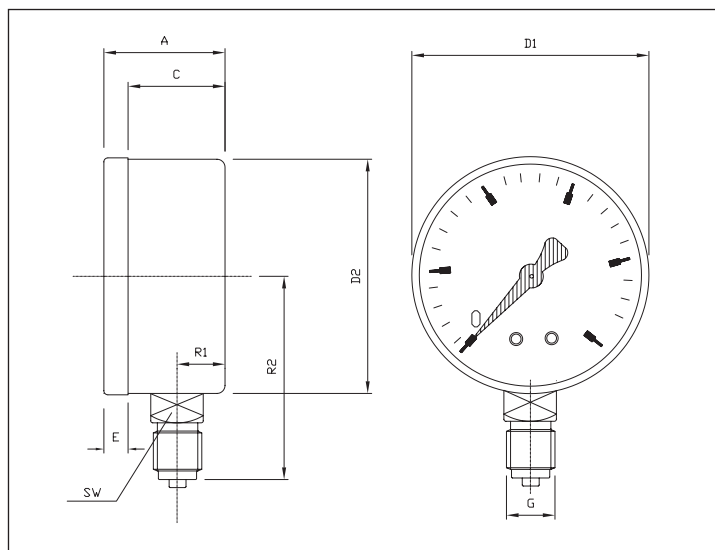

Fig. M 02 01 A (Radial)

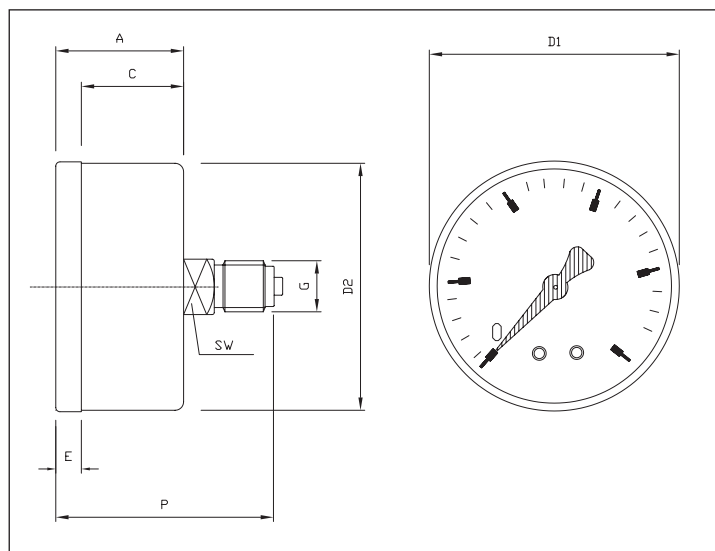

Fig. M 02 01 B (Back centered)

		DIMENSIONS (mm) (tolerances ± 1 mm)										WEIGHT (g)
DN	Connection	RI	A	C	D1	E	D2	G	R2	SW	P	
Ø63	Radial	10	28	17	63	10	62	1/4 BSP	51	14		110
Ø63	Rear		28	17	63	10	62	1/4 BSP		14	46	122
Ø75	Radial	10	30	19	75	11	74	3/8 BSP	60	17		165
Ø75	Rear		30	19	75	11	74	3/8 BSP		17	55	170
Ø100	Radial	16	45	23	100	22	98	1/2 BSP	83	17		383
Ø100	Rear		45	23	100	22	98	1/2 BSP		17	75	405